

INSTRUCTION MANUAL

3-Axis Vibration Meter

VM-54



3-20-41 Higashimotomachi, Kokubunji, Tokyo 185-8533, Japan

<http://www.rion.co.jp/english/>

Organization of this manual

This manual describes the features and operation of the 3-Axis Vibration Meter VM-54.

The manual contains the following sections.

Outline

Gives basic information on the configuration and features of the unit, and contains a block diagram.

Controls and Functions

Briefly identifies and explains all parts of the unit.

Preparations

Explains power supply and pre-use checks, installation, connections, key settings, and other steps.

Reading the Displays

Explains symbols and other information that appears on the two displays of the unit.

Power-On/Off

Explains how to turn the unit on and off.

Measurement

Explains the steps for measurement.

Default Settings

Lists the ex-factory default settings of the unit.

Option Program Installation/Uninstallation

Explains how to install and uninstall the option program software.

Output Connectors

Explains the output connectors of the unit.

Reference Information

Provides additional information that is helpful for using the unit.

Specifications

Lists the technical specifications of the unit.

- * All company names and product names mentioned in this manual are trademarks or registered trademarks of their respective owners.

CE

The product described in this manual is in conformity with the following standards;

EN61000-6-2:2001
EN61000-6-3:2001 + All:2004
ISO/FDIS 8041:2004

Note: CE requirements are met provided that a core filter is fitted to every cable.

To conform to the EU requirement of the Directive 2002/96/EC on Waste Electrical and Electronic Equipment, the symbol mark on the right is shown on the instrument.



FOR SAFETY

In this manual, important safety instructions are specially marked as shown below. To prevent the risk of death or injury to persons and severe damage to the unit or peripheral equipment, make sure that all instructions are fully understood and observed.



Disregarding instructions printed here incurs the risk of injury to persons and/or damage to peripheral equipment.



Disregarding instructions printed here incurs the risk of damage to the product.

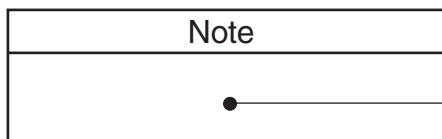

Mentioned about the tips to use this unit properly. (This messages do not have to do with safety.)

Precautions

- Operate the unit only as described in this manual.
- Take care not to drop the unit, and protect it from shocks and vibrations.
- The permissible ambient temperature and humidity range for operation of the unit is -10 to +50°C, 90% RH or below.
Do not use or store the unit in locations that may be subject to extreme temperature or humidity, to splashes of water, high levels of dust, or to direct sunlight. Also avoid air with high salt or sulphur content, gases, and the vicinity of stored chemicals.
- Observe the following precautions after using the unit:
 - Always switch off the power.
 - When the unit is not to be used for an extended period, remove the batteries to prevent possible damage caused by battery leakage.
 - When disconnecting cables, always hold the plug and do not pull the cable. Do not apply excessive force.
- Clean the unit only by wiping it with a soft, dry cloth or, when necessary, with a cloth lightly moistened with water. Do not use any solvents, cleaning alcohol or cleaning agents.
- Do not tap the LCD panel or other surfaces of the unit with a pointed object such as a pencil, screwdriver, etc.
- Do not insert any objects such as pins, metal scraps, conducting plastic etc. into any opening on the unit.
- Do not disassemble the unit or attempt internal alterations.
If you suspect that there is a problem with the unit, contact your supplier.
- Have the unit checked and serviced regularly.
- When disposing of the unit, follow national and local regulations regarding sorting and recycling of materials.

Contents

FOR SAFETY.....	iii
Precautions.....	v
Outline.....	1
Controls and Functions	3
Front panel	3
Input/output section	3
Display section	4
Control section	4
Right side view	8
Bottom view	9
Preparations	11
Power supply	11
Accelerometer connection	14
Connection to external device (level recorder, DAT etc.)	16
Setting the date and time	17
Backup battery.....	18
Measurement in dark locations	19
Adjusting the sub display contrast	20
Calibration	21
Reading the Displays	23
Main display	23
Sub Display	25
Menu screens	28
Power-On/Off	31
Power-on	31
Power-off	32
Measurement	33
Instantaneous value measurement (acceleration rms value measurement)	33
Maximum hold	35

Default Settings	37
Option Program Installation/Uninstallation	38
Installing the option program	39
Program installation failure	41
Uninstalling the option program	42
Output Connectors	43
AC Output	43
Reference Information	44
About the external power switching jumper pins	44
Input connector	46
Frequency characteristics	47
Specifications	48

Outline

The VM-54 is a vibration meter capable of measuring acceleration in three axes X, Y, Z. The unit can be used with the 3-axis accelerometer PV-83C/PV-83CW, and various other sensors such as piezoelectric accelerometers and accelerometers with built-in preamplifier can also be connected via a 3ch preamplifier VP-80. Two measurement modes are available, namely instantaneous value and maximum value hold. AC outputs for X, Y, Z allow connection of a general-application data recorder or a DAT recorder. The optional Marine Vibration Card VX-54WS as well as other option program cards for hand-arm vibration measurement and whole-body vibration measurement enable use for a wide range of applications to evaluate the influence of vibrations upon humans.

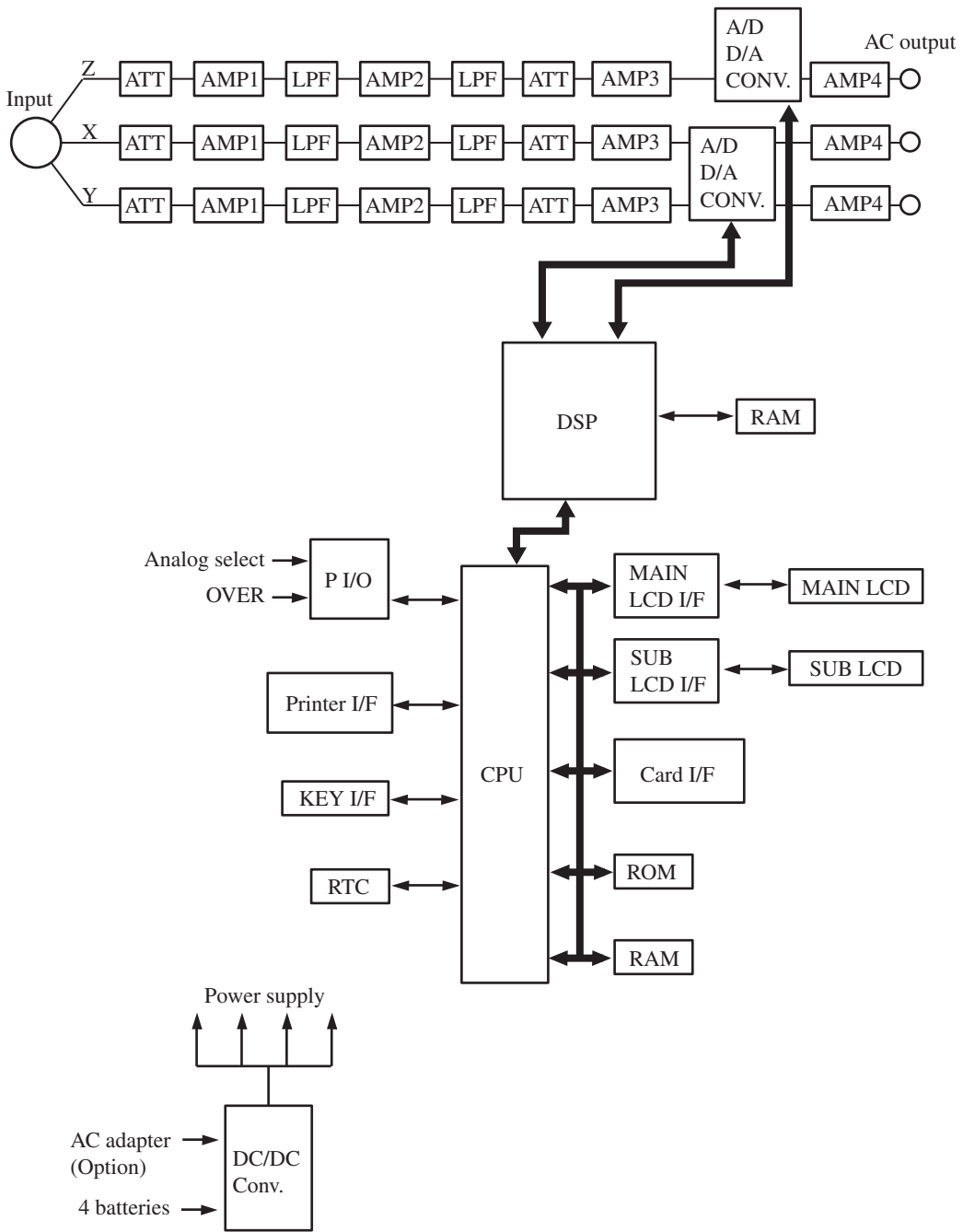

3-Axis Vibration Meter VM-54 Block Diagram

Controls and Functions

Front panel

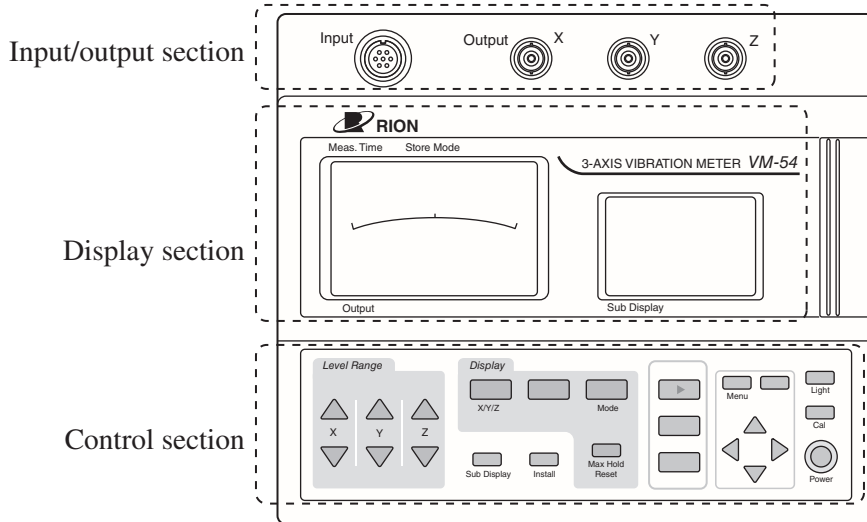

Input/output section

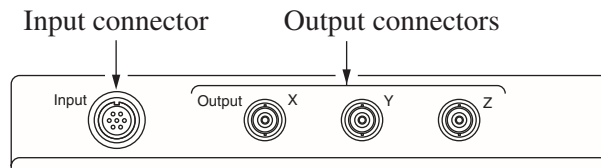

Input connector

The 3-axis accelerometer PV-83C/PV-83CW can be connected here, using connection cable EC-54 (optional).

To connect a piezoelectric accelerometer or accelerometer with built-in preamplifier, use the optional 3ch preamplifier VP-80.

Output connectors

These are BNC connectors which carry an AC output signal for the X, Y, and Z axis.

Display section

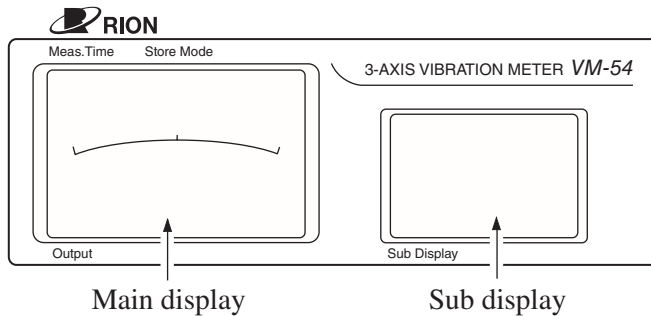

Main display

Shows the instantaneous value, maximum hold value, and setting information.

Sub display

Shows the bar graph screen, 3-axis measurement screen and other measurement screens. The sub display also shows menus.

Control section

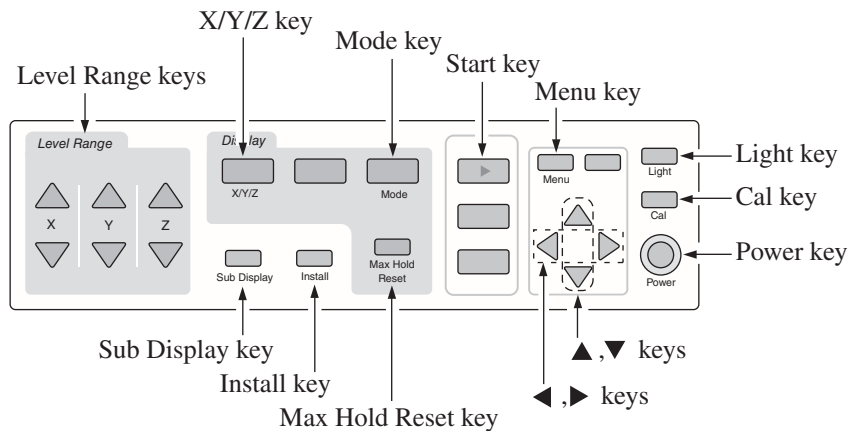

Note

Protective film

The unit is shipped with a protective film covering the operation panel. When using the unit, you can remove this film.

Level Range keys

These keys control the level range for the X, Y, Z axis.

The ▲ key switches the level range up, and the ▼ key switches the level range down.

X/Y/Z key

Switches the vibration axis to be shown on the display.

With each push of the key, the display cycles through the settings in the order X → Y → Z → X etc.

Mode key

Switches the display mode.

Each push of the key cycles toggles between instantaneous value and Max Hold (maximum value hold).

Start key

Serves to set the date and time (page 17) and make default settings (page 37).

Menu key

Pressing this key brings up a menu screen 1/2 on the sub display.

Pressing the key changes the menu screen 1/2 to 2/2. Pressing the key again closes the menu display. When an option program is installed, the menu has three pages in VM-54 mode.

The menu can also be closed by pressing any other key except the Light key, Power key, and ▲, ▼, ◀, ▶ keys.

Light key

This key turns the backlight for the main display and sub display on. This is convenient when using the unit in a dark place. To turn the backlight off, press the key again.

When the unit is operating on battery power, the backlight will be automatically turned off after 10 minutes. When the unit is powered from an external power supply, the backlight will not be automatically turned off.

Battery current consumption increases by a factor of about 2 when the backlight is on.

Cal (Calibration) key

This key serves for level matching between the outputs of the unit and peripheral equipment.

If you press the Cal key immediately after power-on, while the initialization screen is still shown, the software version of the VM-54 will be displayed.

Power key

Serves to turn the unit on and off.

Hold down the key for at least one second to turn power on or off.

After switching the unit off, wait at least five seconds before turning power back on again. Otherwise the unit may not start up properly.

▲, ▼ keys

When the sub display is showing a menu screen, these keys serve to select a menu item.

◀, ▶ keys

When the sub display is showing a menu screen, these keys serve to change the setting of the selected item.

Max Hold Reset key

Resets the value of the maximum hold function.

Install key

To install or uninstall an optional program, hold down this key while turning on the unit with the Power key.

Sub Display key

Switches the function mode of the sub display.

With each push of the key, the display cycles through the 3-axis bar graph screen, 3-axis measurement screen, and settings check screen.

Unnamed keys (indicated by * symbol)

The four unnamed keys (indicated by a * symbol in the illustration below) have no function in the normal operation mode of the VM-54. If you press one of these keys, the indication "Invalid operation!" appears on the sub display.

These keys perform certain functions only when one of the option programs (for marine vibration measurement, hand-transmitted vibration measurement, or whole-body vibration measurement) is installed.

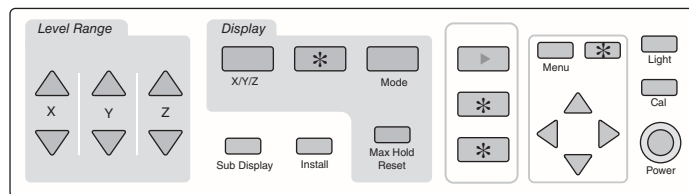

Right side view

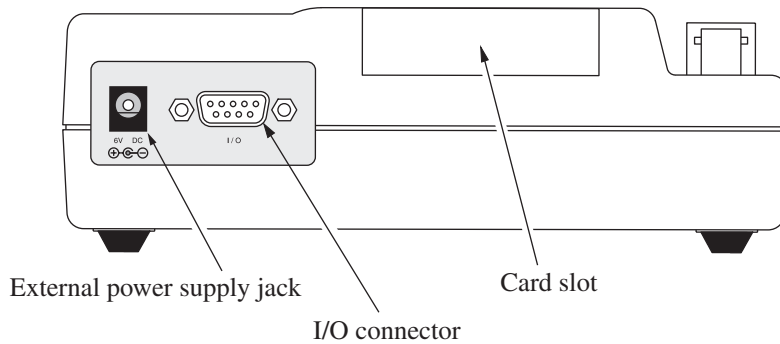

External power supply jack

The optional AC adapter NC-98B (NC-98A, NC-98) (for 100 to 240 V AC) can be connected here to power the unit from an external source.

I/O connector

This connector has no function in the normal operation mode of the VM-54. The connector provides a printer output signal only when one of the option programs is installed.

Card slot

One of the option program cards can be inserted in this slot. In the VM-54, this slot does not function as a regular memory card slot for saving data.

Bottom view

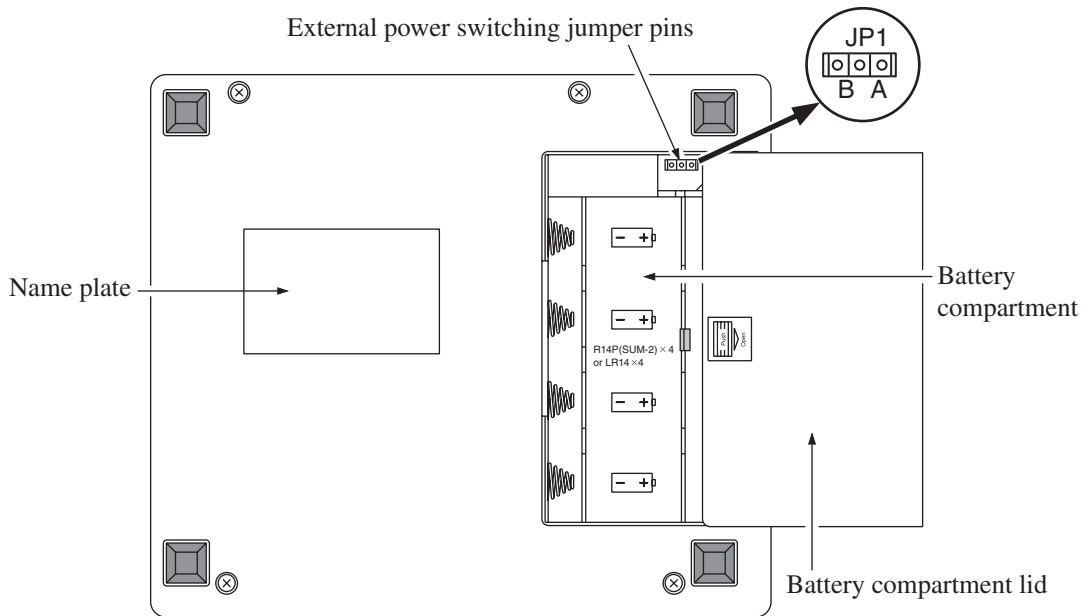

Battery compartment

Holds four IEC R14 (size "C") batteries.

External power switching jumper pins

Normally, the supplied jumper should be set on the side marked "A" (



If the jumper is set to the side marked "B" () , the VM-54 comes on even without pressing the Power key when the external power supply becomes active.

Caution

The external power switching jumper pins are small and pointed. Take care not to hurt your fingers.

Important

Never connect any equipment to the external power switching jumper pins. Otherwise damage can occur.

Name plate

Shows the serial number of the unit as well as the manufacturing date and other information.

Preparations

Power supply

The VM-54 can be powered from four IEC R14 (size "C") batteries (alkaline or manganese), or from the AC adapter NC-98B (NC-98A, NC-98).

It is also possible to use rechargeable IEC R14 (size "C") batteries, but the VM-54 does not have a facility for recharging such batteries.

Note

When an AC adapter is connected to the VM-54, power will be supplied by the adapter also if batteries are inserted. However, if power from the AC adapter is interrupted (for example due to a power line blackout), the VM-54 will automatically switch to battery operation.

Batteries

1. Remove the battery compartment lid on the bottom panel.
2. Insert four IEC R14 (size "C") batteries with correct orientation, as shown in the battery compartment.
3. Replace the battery compartment lid.

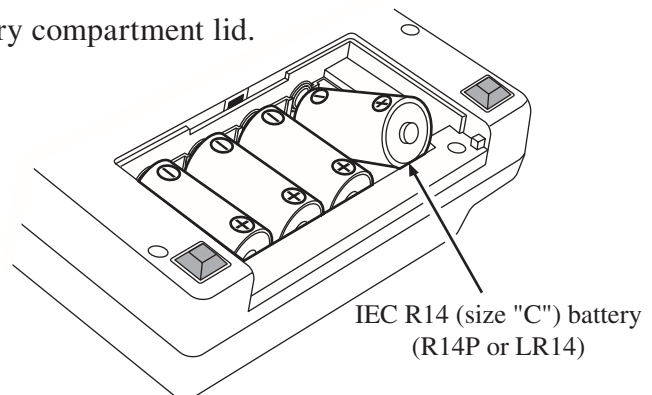

⚠ Caution

Take care not to insert batteries with wrong + and - polarity. Otherwise battery fluid may leak, or the batteries may overheat, emit smoke, or explode.





Battery life will differ, depending on the battery type, usage conditions, and other factors.

Approximate battery life

(at 20°C, with accelerometer PV-83C connected, backlight OFF)

Battery life with continuous operation		
Alkaline batteries	LR14	approx. 22 hours
Manganese batteries (black)	R14PU	approx. 8.5 hours

When the backlight is used, current consumption will increase by a factor of about 2.

Important		
<p>Always replace all four batteries at the same time, and do not mix different types of batteries or old and fresh batteries. Otherwise damage may occur.</p> <p>While not using the unit, the batteries should be removed.</p> <p>When the battery capacity indicator flashes, you should replace the batteries. Correct measurement is not possible in this condition.</p>		
 Batteries good		 Batteries low
		 Flashing Replace batteries

Note
<p>When the unit is operating on batteries, power may not come on if the ambient temperature is lower than 10°C (because the voltage of older batteries may have dropped below the required threshold). In such a case, replace all four batteries with fresh alkaline batteries.</p> <p>If the unit is to be operated on battery power for a long time, the separately available battery pack BP-21 is recommended. This uses four IEC R20 (size "D") alkaline batteries which give a continuous operation time of about 72 hours (at room temperature).</p>

AC adapter (option)

Connect the AC adapter as shown in the illustration below.

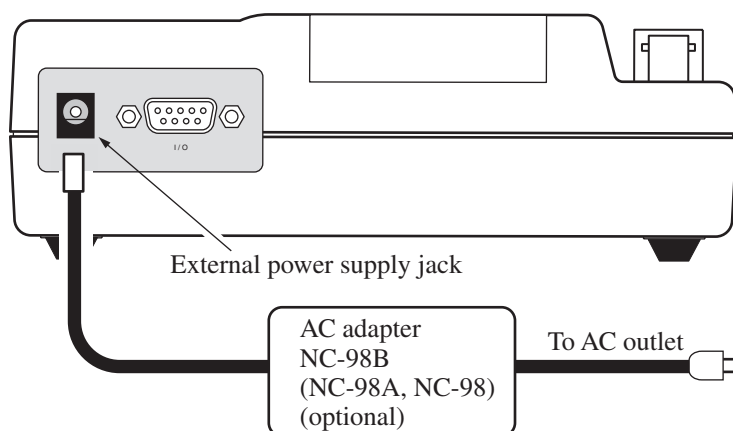

Note

The optional AC adapter NC-98B (NC-98A, NC-98) is for 100 to 240 V AC.

Important

Do not use any other kind of AC adapter except the NC-98B (NC-98A, NC-98) Otherwise damage may occur.

Power consumption

Approx. 5.5 VA (with AC adapter NC-98B (NC-98A, NC-98) at 100 V AC)

Accelerometer connection

When using 3-axis accelerometer PV-83C/PV-83CW

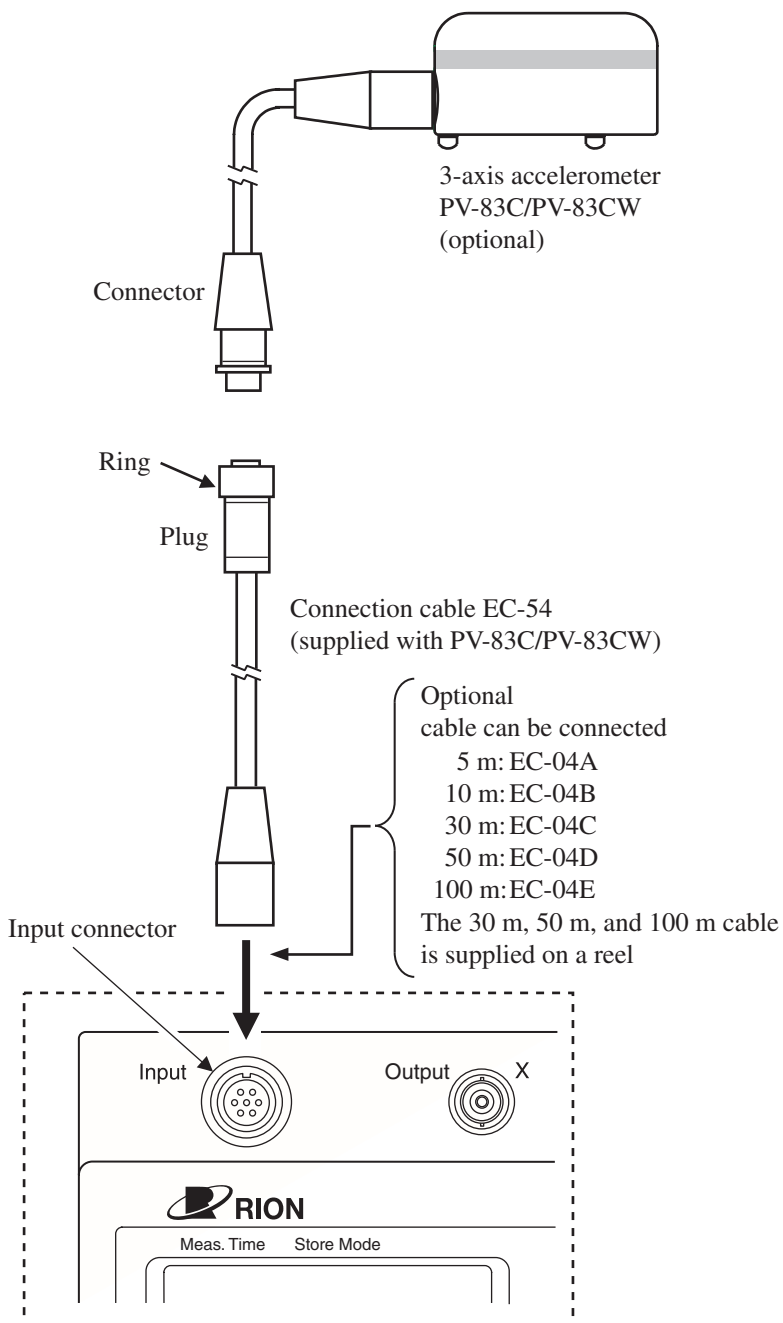

Note

When the 3-axis accelerometer PV-83C/PV-83CW is connected, the frequency range is 1 to 80 Hz.

When using a piezoelectric accelerometer

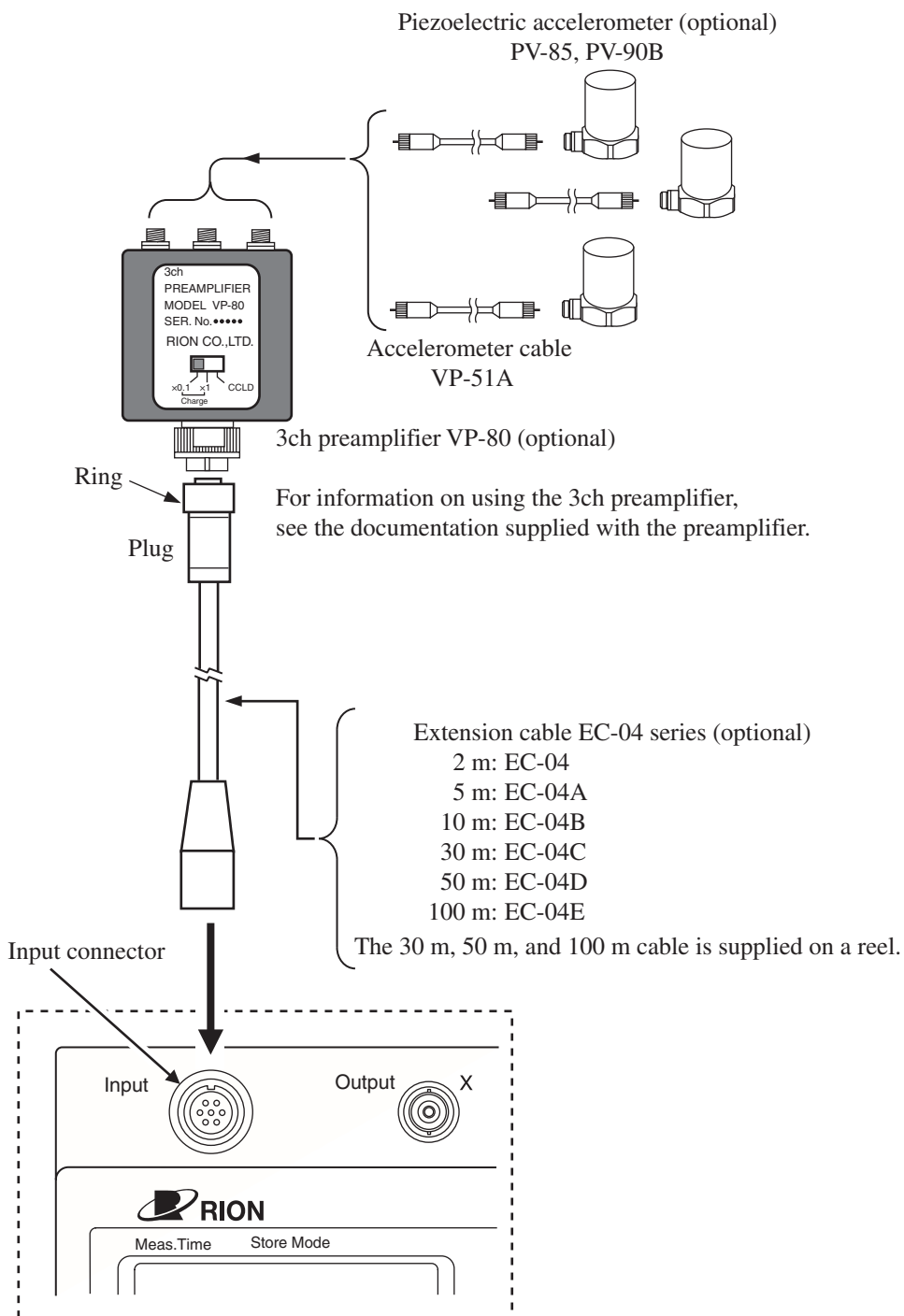

Connection to external device (level recorder, DAT etc.)

The output connectors of the unit (X or Y or Z) can be connected to the input of an external device using the BNC-BNC cable NC-39A (optional).

The connectors carry an AC signal.

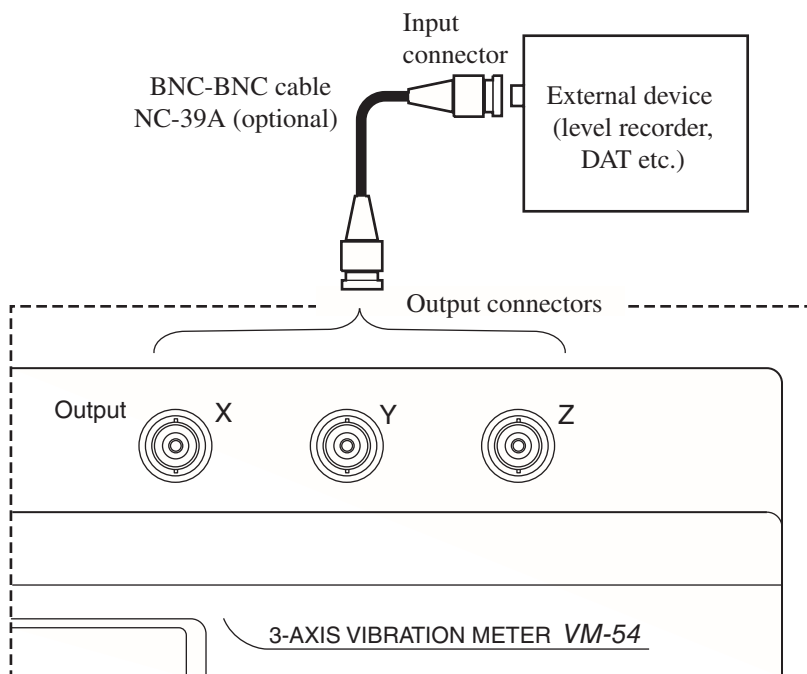

Setting the date and time

The VM-54 incorporates a clock.
Set the date and time as follows.

1. Press the Power key to turn the unit on.
2. Press the Menu key to bring up the menu screen 2/2 on the sub display.

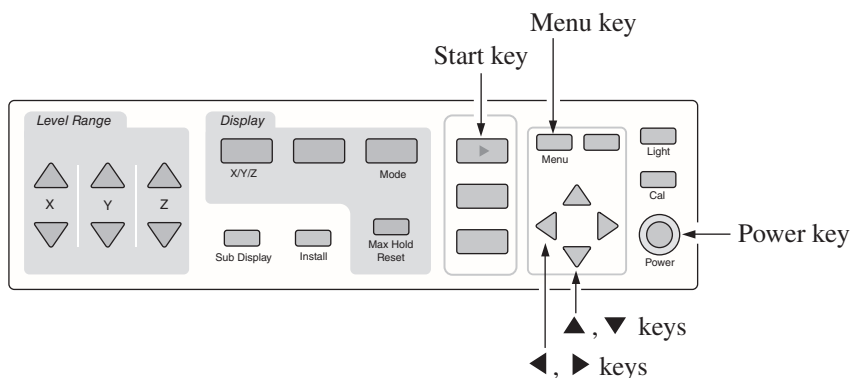

3. Use the ▲ and ▼ keys to highlight the date or time item that you want to change, and use the ◀ and ▶ keys to change the setting.

Sub display

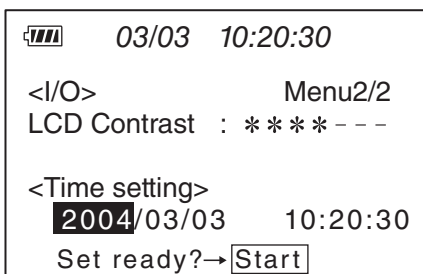

Use ▲ and ▼ keys
to move highlight
Use ◀ and ▶ keys
to change value

Menu screen 2/2

4. Press the Start key.
The internal clock is set to the selected date and time.
5. Press the Menu key to turn off the menu display.

Note
The clock IC used in this unit has an error of about 1 minute per month. Before measurement, be sure to check and set the time if required.
An internal rechargeable backup battery keeps the clock of the unit running when the power is turned off. If the unit is not to be used for an extended period, the main batteries should be taken out to prevent possible damage due to battery fluid leakage. After reinserting the batteries, be sure to set the date and time.

Backup battery

The VM-54 incorporates a backup battery (rechargeable) for clock data backup.

The battery is recharged automatically while power to the VM-54 is on. (not recharged while the power is off).

It takes about 12 hours to reach a full charge.

With a full charge, data will be retained for about 1.5 months. If this period is exceeded, clock data will be lost. It is therefore recommended to ensure that the battery is charged.

The service life of the backup battery is limited. You should have the battery replaced about once every five years. In such case please contact your dealer.

Note
When the backup battery is old, the data retention period will be shorter.

Important
A full charge is achieved by leaving power to the VM-54 on for 12 hours.

Measurement in dark locations

Pressing the Light key turns the display backlight on, making it easier to read in dark locations. Pressing the key once more turns the light off.

When the backlight is used, current consumption will increase by a factor of about 2.

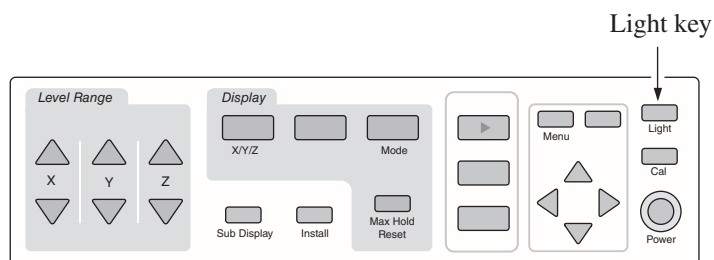

Note

When the unit is operating on battery power, the backlight will be automatically turned off after 10 minutes.

Adjusting the sub display contrast

You can adjust the contrast of the sub display as follows.

1. Press the Menu key.

The menu screen appears on the sub display.

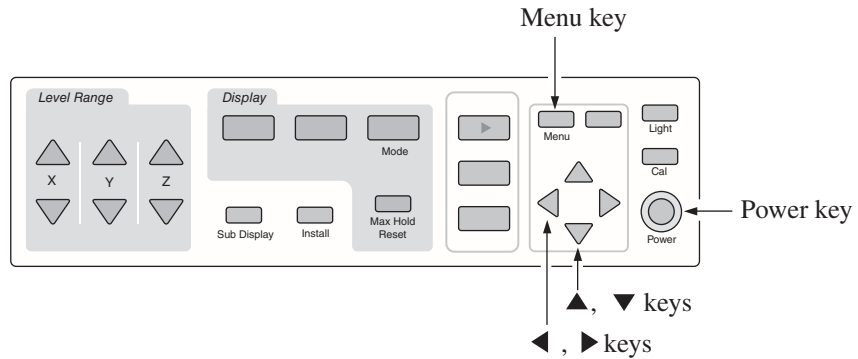

2. Press the Menu key until the indication "Menu 2/2" is shown in the top right of the display.
3. Use the ▲ and ▼ keys to highlight the [****---] area of the item "LCD Contrast".

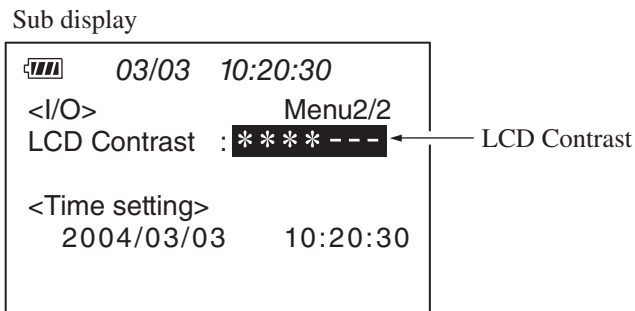

Menu screen 2/2

4. Use the ◀ and ▶ keys to increase or decrease the "*" symbols. This changes the contrast.
5. Press the Menu key several times to return to the menu screen.

Note

The contrast for the main display cannot be changed.

Calibration

When using external equipment to record measurement data, level calibration should be performed as follows.

1. Press the Power key to turn the unit on.
2. Press the Cal key.

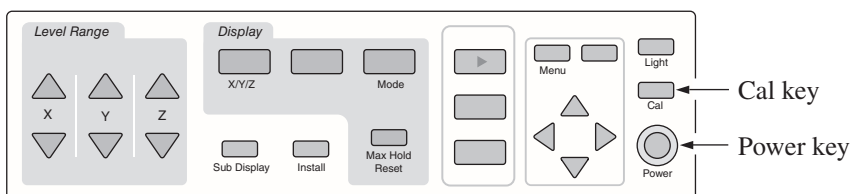

The main display and sub display go into calibration mode.

The vibration direction for the main display can be switched with the X/Y/Z keys.

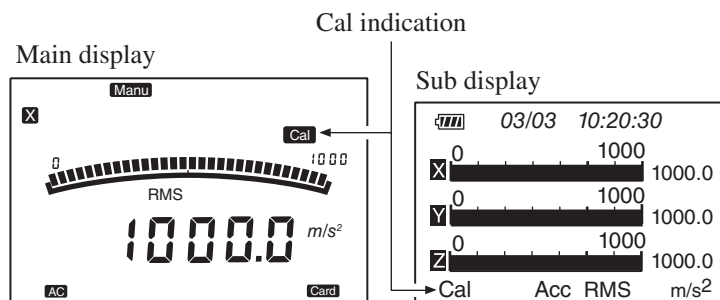

Main display and sub display in calibration mode

The sub display automatically is fixed to 3-axis bar graph mode, letting you directly check the measurement values for the 3 axes.

During calibration, the following signal is supplied at the Output connectors.

31.5 Hz, 1 Vrms, AC

When using an external device (level recorder, analyzer or similar) for measurement, this signal should be used to calibrate the device.

3. Press the Cal key again to turn calibration mode off.

Note

With the range settings 0.03, 0.3, 3, 30, 300, and 3000, the range full scale value is 0.0316, 0.3162, 3.162, 31.62, 316.2, and 3162 respectively.
--

Reading the Displays

The VM-54 has two LCD panels. The left-side panel is the main display and the right-side panel is the sub display.

The main display shows the measurement value and settings for the selected vibration axis (X, Y, Z).

The sub display shows the 3-axis bar graph, 3-axis measurement screen, menu screens, and other information, depending on the selected mode.

Main display

The illustration below is for demonstration purposes only. In actual use, not all display elements will be visible at the same time.

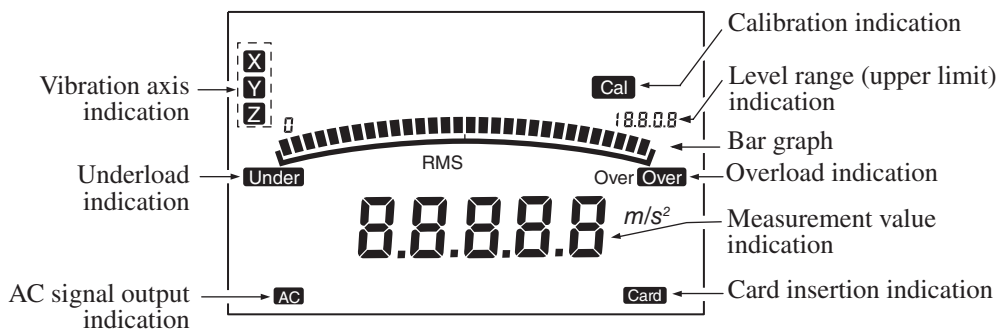

Calibration indication

Appears when the Cal key was pressed and the unit is in calibration mode.

Level range (upper limit) indication

Shows the maximum value (range full-scale) for the bar graph, as set with the level range keys.

Note

With the range settings 0.03, 0.3, 3, 30, 300, and 3000, the range full scale value is 0.0316, 0.3162, 3.162, 31.62, 316.2, and 3162 respectively.

Bar graph

A bar graph corresponding to the measurement value is shown here. The display update frequency is 100 ms.

Overload indication (**Over** shown in reverse)

Appears when overload in the instantaneous value was detected.

Overload indication ([Over] shown in normal mode)

Appears when overload is included in the maximum hold value.

Measurement value indication

The measurement result is shown here. The display update frequency is 1 s.

Card insertion indication

Appears when a memory card is inserted in the card slot.

AC signal output indication

AC: Output connectors supply AC signal.

Underload indication

Appears when underload in the instantaneous value was detected.

Vibration axis indication

Shows which vibration axis is currently selected for measurement value indication.

The axis is selected with the X/Y/Z keys.

Main display example

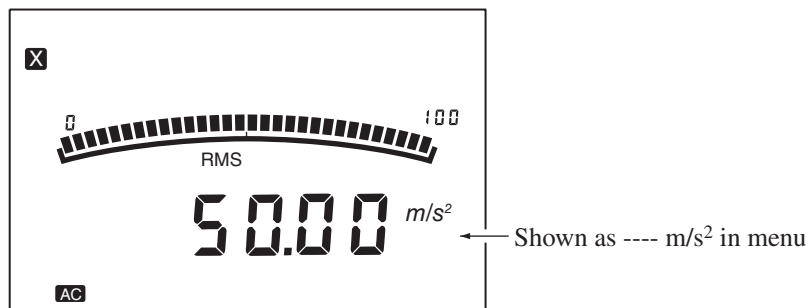

Sub Display

The sub display employs a dot-matrix type LCD which allows various display functions.

The Sub Display key serves to switch between these functions. The screen also changes according to the operation mode.

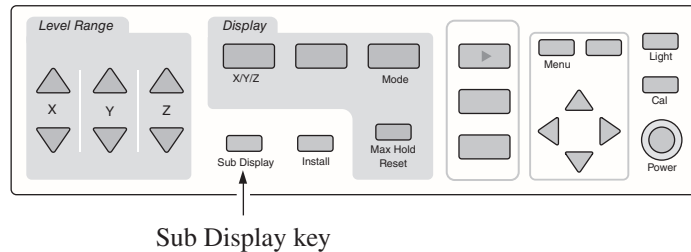

The battery capacity and date/time indications also appear on the sub display.

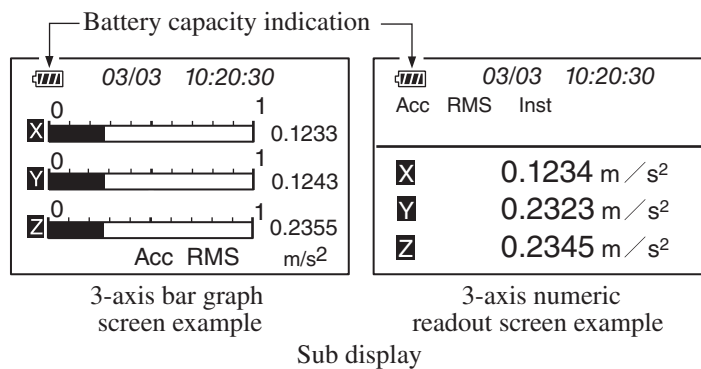

During instantaneous value measurement

The 3-axis bar graph, 3-axis numeric readout, or settings screen can be selected.

Battery capacity indication

When the unit is operating on battery power, you should periodically check the battery capacity indicator. The number of black segments decreases as the batteries are used up. When the display starts to flash, correct measurement is no longer possible. Replace the batteries with a fresh set.

While the unit is powered from the AC adapter, the battery capacity indication is at maximum.

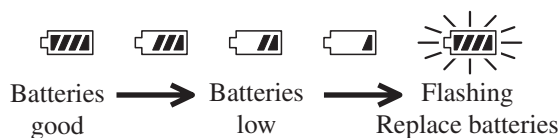

3-axis bar graph screen

This screen shows bar graphs for all three axes and the instantaneous values simultaneously.

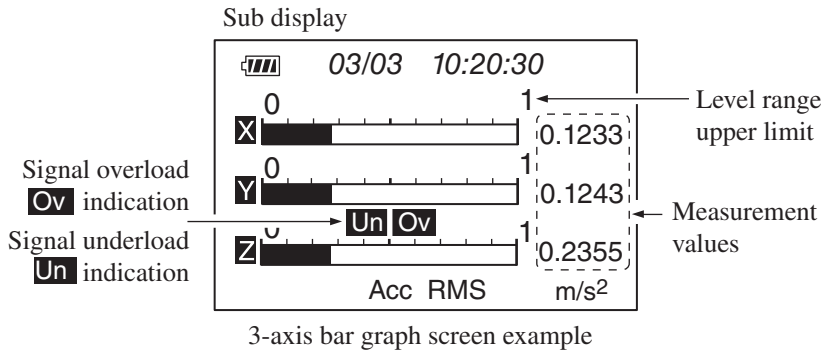

3-axis measurement value display

The measurement values for the 3 vibration axes are shown as a numeric readout.

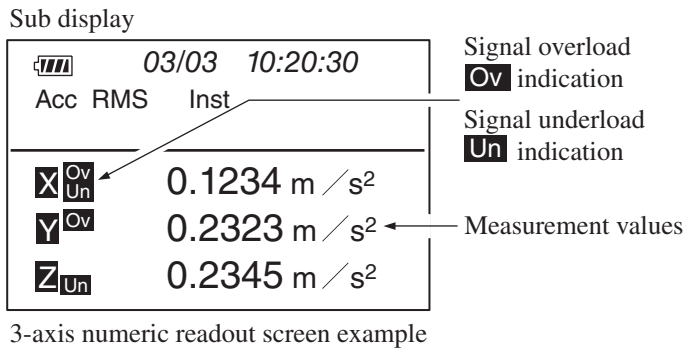

Settings screen

The settings for sensor, level range etc. are shown on this screen, for confirmation.

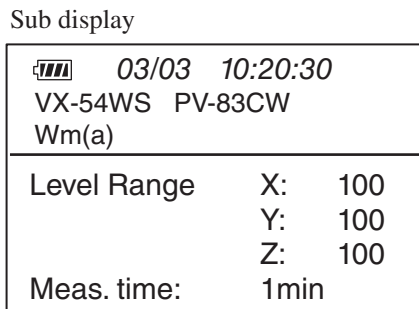

Calibration mode

In calibration mode, the display is automatically switched to 3-axis bar graph mode.

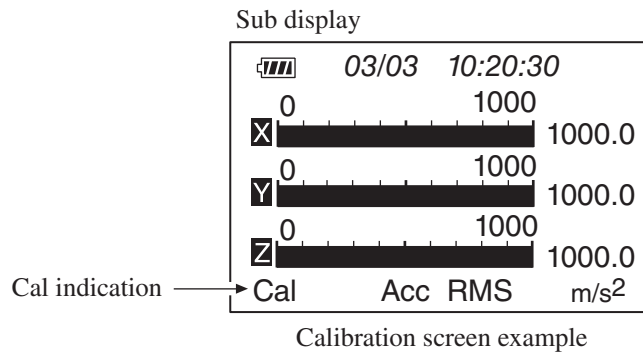

Menu screens

The VM-54 has two menu pages which are shown on the sub display and are numbered 1/2 and 2/2. The Menu key lets you switch between these pages.

To select an item on a menu screen, use the ▲ and ▼ keys.

To change the setting of an item, use the ◀ and ▶ keys.

Note

When an option program is installed, the number of menu pages is different.

Menu screen 1/2

The display contents will change, according to the sensor type setting.

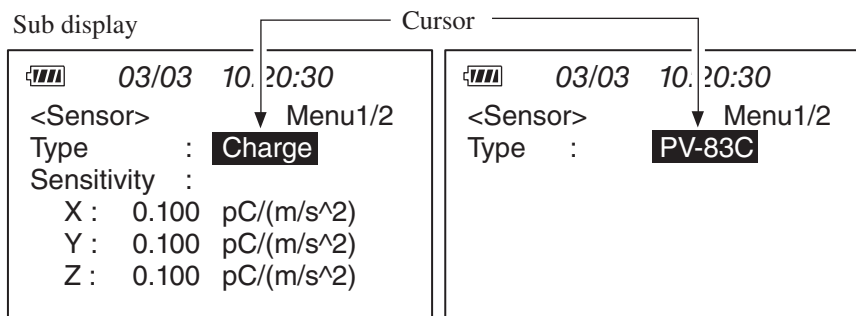

Menu screen 1/2 (Type: Charge)

Menu screen 1/2 (Type: PV-83C)

Sensitivity when "Type" is set to "Charge"

Unit: pC/(m/s²)

Setting range: 0.0100 to 0.0999 0.0001 step

0.100 to 0.999 0.001 step

1.00 to 9.99 0.01 step

10.0 to 99.9 0.1 step

When PV-57(A) is used, set the Z channel sensitivity to 5.10 pC/(m/s²)

Sensitivity when "Type" is set to "CCLD"

Unit: mV/(m/s²)

Setting range: 0.0100 to 0.0999 0.0001 step

0.100 to 0.999 0.001 step

1.00 to 9.99 0.01 step

10.0 to 99.9 0.1 step

When the PV-83C is used, the Sensitivity item is not shown. Sensitivity is set automatically to match the PV-83C. Select the PV-83C setting also when PV-83CW is used.

Menu screen 2/2

To select an item on a menu screen, use the ▲ and ▼ keys to move the cursor.

To change the setting of an item, use the ◀ and ▶ keys.

The menu screen 2/2 contains the LCD Contrast setting and the Time setting (date and time) items. For information on how to change these, see "Setting the date and time" on page 17.

Sub display

 03/03 10:20:30
<I/O> Menu2/2
LCD Contrast : * * * * - - -
<Time setting>
2004/03/03 10:20:30

Menu screen 2/2

Note
Changes made on a menu screen become valid when you close the menu screen.

Power-On/Off

Power-on

Hold down the Power key for about 1 to 2 seconds until the sub display shows the power-on screen. When the screen appears, release the Power key. After the initialization screen was shown, the measurement screen appears.

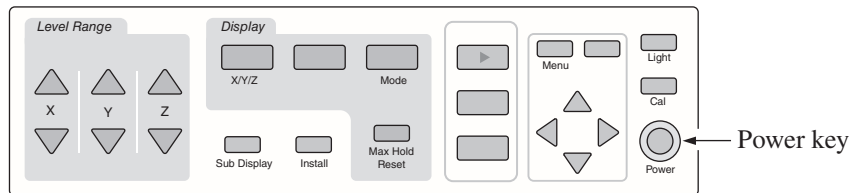

Sub display screen during power-on
(initialization screen)

Note

By pressing the Cal key while the above initialization screen is shown, you can bring up the software version display. Press the Cal key once more to go to the measurement screen.

Power-off

Hold down the Power key for about 1 to 2 seconds until the sub display shows the power-off screen. When the screen appears, release the Power key.

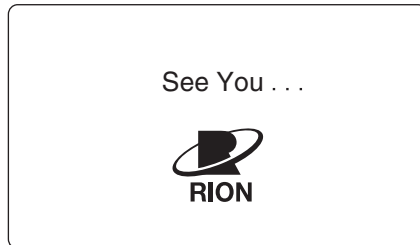

Sub display screen during power-off

Note
After turning the unit off, wait at least 5 seconds before turning power back on again.

Measurement

The VM-54 can measure vibration acceleration in three directions. You can select either instantaneous value measurement or maximum hold measurement mode.

Instantaneous value measurement (acceleration rms value measurement)

The procedure for instantaneous value measurement is as follows.

1. Press the Power key to turn the unit on.
(For information about the display, see the section "Power-On/Off" on page 31.)

The measurement settings that were selected when the unit was last turned off will be active again. Therefore the display at power-on will not always be the same.

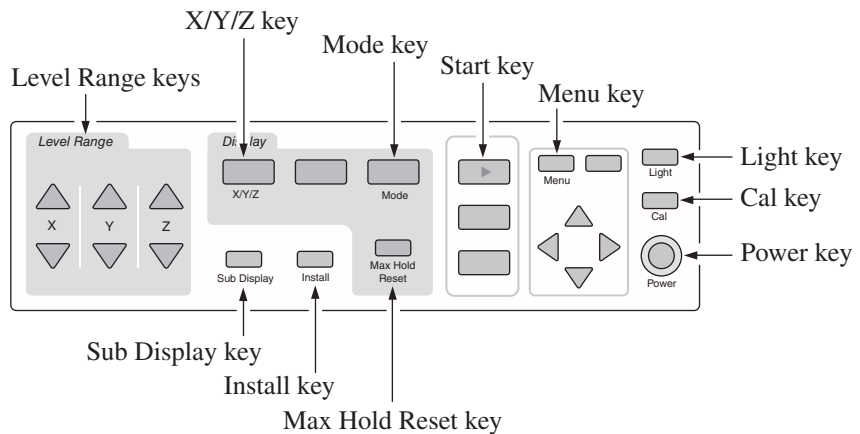

2. Use the X/Y/Z key to select the vibration axis.

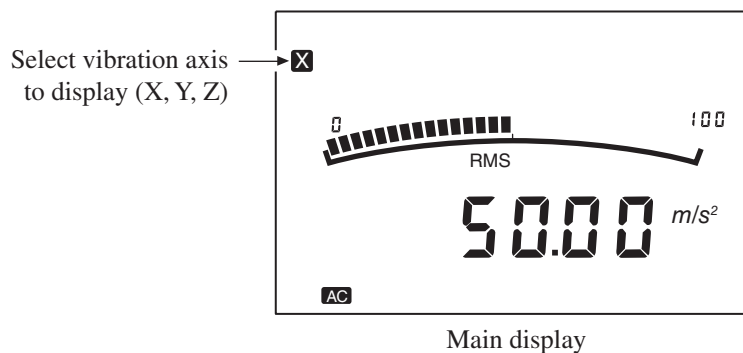

3. Select the level range with the Level Range keys.
 If [Over] is shown frequently, change the level range setting.
 The measurement value indicated on the display is the acceleration rms value.
 The reading is updated every second.
 The bar graph is updated in 0.1 second intervals.

Main display

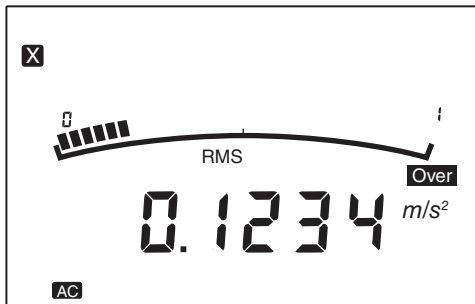

Instantaneous value (acceleration rms value) measurement display example

Sub display

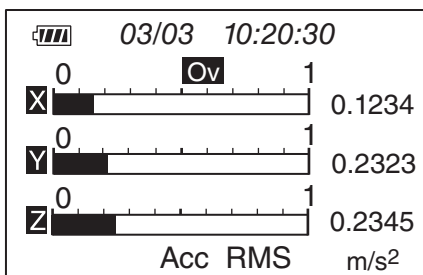

3-axis bar graph screen example

Sub display

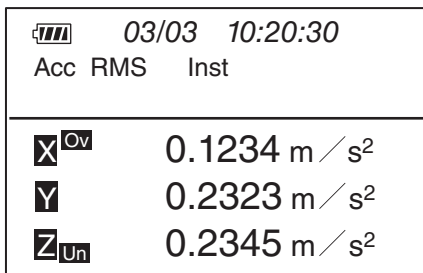

3-axis numeric readout screen example

Note
The 3-axis bar graph screen on the sub display lets you also check the measurement value.

Maximum hold

The maximum of the measured acceleration rms value can be retained by the unit without time limitation.

1. Press the Power key to turn the unit on.
(For information about the display, see the section "Power-On/Off" on page 31.)

The measurement settings that were selected when the unit was last turned off will be active again. Therefore the display at power-on will not always be the same.

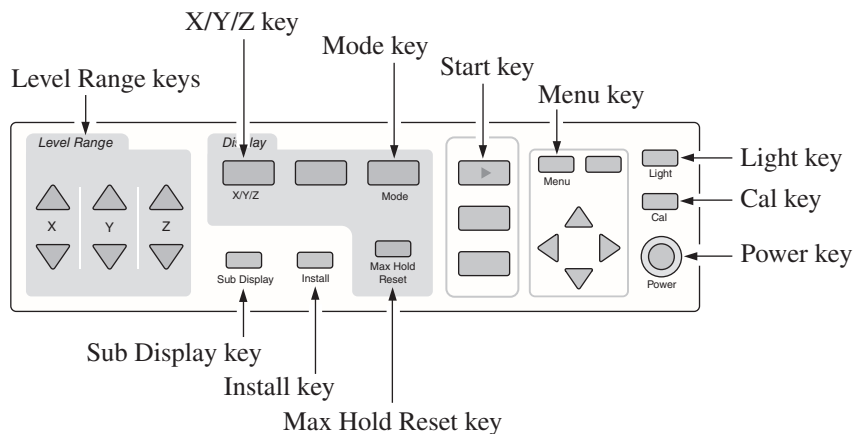

2. Use the X/Y/Z key to select the vibration axis.
3. Select the level range with the Level Range keys.
If [Over] is shown frequently, change the level range setting.
4. Press the Mode key to switch the instantaneous value display to maximum value hold ("max hold").

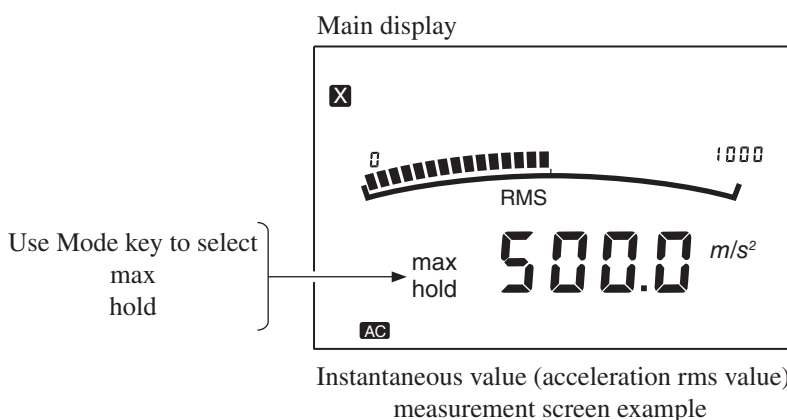

5. Press the Max Hold Reset key to reset the memorized maximum hold data. Maximum hold measurement automatically starts at this point. The value shown on the measurement display is the maximum of the acceleration rms value. The hold condition does not apply to the bar graph display. If an overload condition has occurred at any point in the measurement, the indication "Over" is shown to indicate that the maximum hold value includes overload.

If settings were changed (for example level range was switched during measurement), correct measurement is not possible. After changing any setting, press the Max Hold Reset key to reset the maximum hold data.

Main display

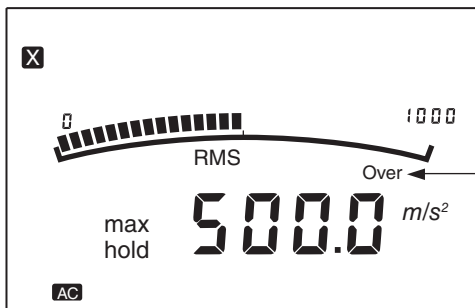

Measurement screen example

Over is shown when maximum hold value includes overload data

Default Settings

The ex-factory default settings of the VM-54 are as shown below.

Main display: Instantaneous value measurement screen

Sub display: 3-axis bar graph

Level range: 10 m/s²

Menu 1/2

Sensor Type: PV-83C

Default sensitivity settings when Sensor Type is Charge or CCLD:

X = 5.00 pC/(m/s²)

Y = 5.00 pC/(m/s²)

Z = 5.00 pC/(m/s²)

Menu 2/2

LCD Contrast: ***** - -

If you hold down the Start key while turning on the power, the unit starts up with the above settings.

The internal clock setting is not affected by this.

Option Program Installation/Uninstallation

The Marine Vibration Card VX-54WS is available as an option program for the VM-54. The program data on the card are protected, allowing installation only on one VM-54 at a time.

Important

If the power is interrupted during installation or uninstallation, the unit may malfunction. When performing the procedure while powering the VM-54 from batteries, make sure that the batteries are fresh. When performing the procedure while powering the VM-54 from the AC adapter, make sure that batteries are inserted as a backup power supply.

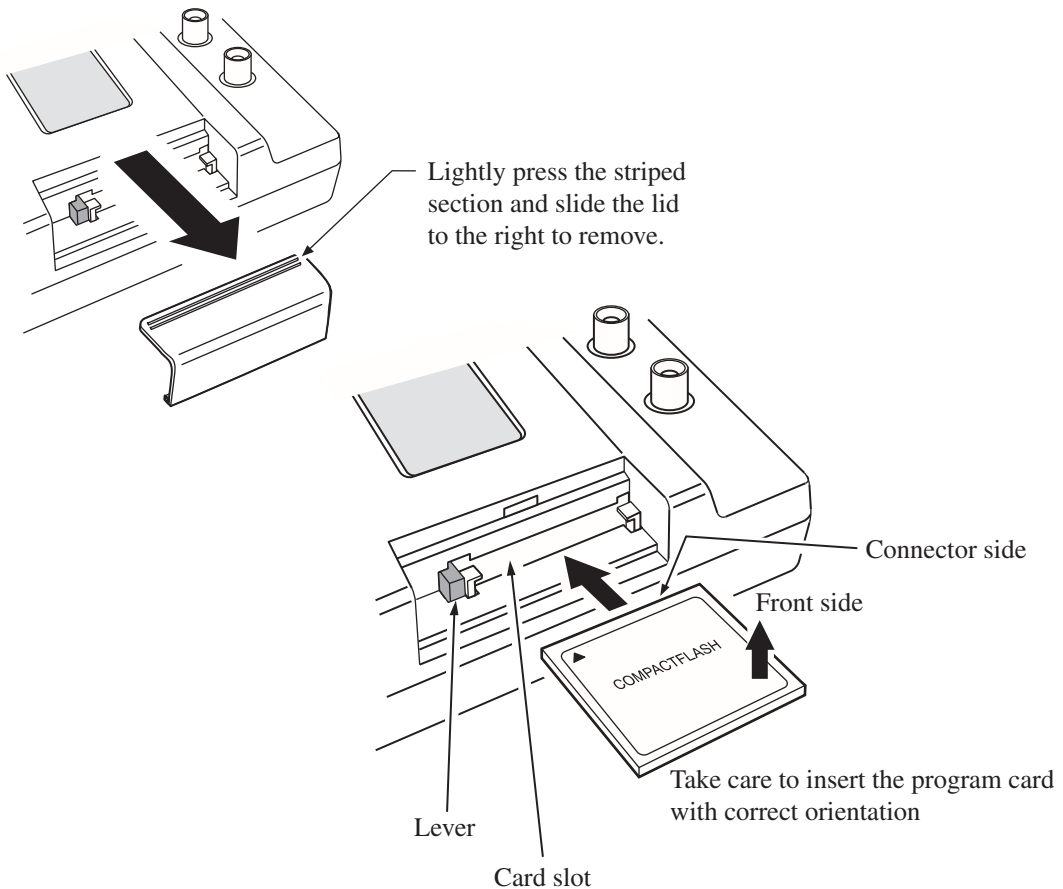

To remove the program card, press this lever.

Installing the option program

Important

Make sure that power is turned off before inserting the card.

The procedure for installing an option program into the VM-54 is as follows.

1. Open the lid of the card slot and insert the program card.
2. While holding down the Install key, press the Power key to turn the unit on.

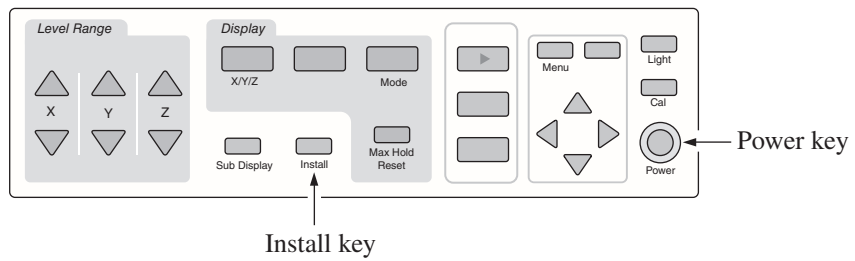

3. The screen for installing an option program appears. To proceed with the installation, press the Mode key.

Sub display

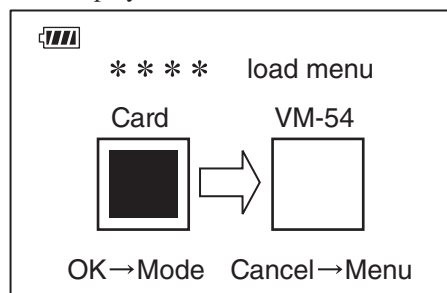

Installation confirmation screen

- (black): Program is loaded
- (white): Program is not loaded

Note

After installing the option program on one VM-54, the card can no longer be used to install the program on any other VM-54. To install the option program on another VM-54, you must first uninstall it from the VM-54 where it was installed initially.
--

When the installation is complete, the measurement screen appears and the option program can be used.

If you want to cancel the installation, press the Menu key instead of the Mode key at the installation confirmation screen. The normal measurement screen will appear.

Program installation failure

If you insert a program card whose program data have already been installed into another VM-54, a screen such as shown below will appear, indicating that the program cannot be installed.

Sub display

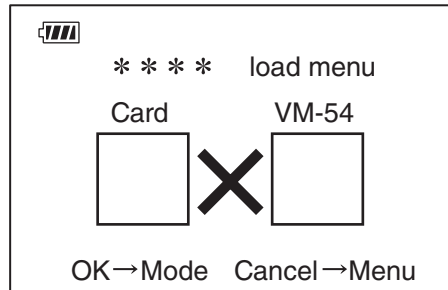

Uninstall failure screen

Press any key except the Power key to abort the installation.

If you insert a program card whose program data have not yet been installed into a VM-54 where the option program is already installed, a screen such as shown below will appear, indicating that the program cannot be installed.

Sub display

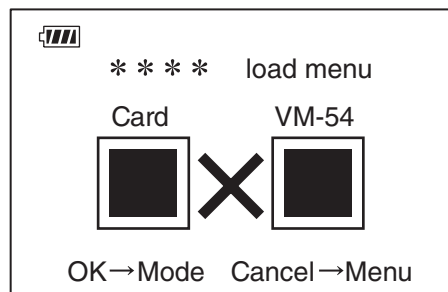

Install failure screen

Press any key except the Power key to abort the installation.

Important

Never remove the program card while the option program is being installed. Otherwise damage may occur.

To remove the program card, turn power to the VM-54 off and then press the lever in the card slot.

Uninstalling the option program

The procedure for uninstalling an option program from the VM-54 is as follows.

1. Open the lid of the card slot and insert the program card.
2. While holding down the Install key, press the Power key to turn the unit on. If an option program is installed, the uninstallation screen appears.

Sub display

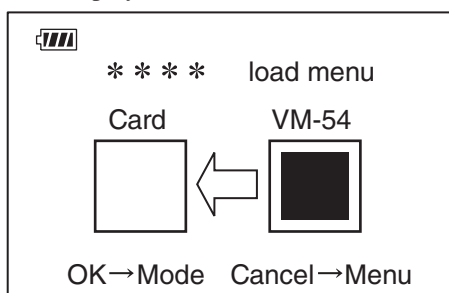

Uninstallation confirmation screen

To proceed with the uninstallation, press the Mode key. The option program is uninstalled from the VM-54 and the program card becomes valid again. When the uninstallation process is complete, the measurement screen appears again.

If you want to cancel the uninstallation, press the Menu key instead of the Mode key at the uninstallation confirmation screen. The normal measurement screen will appear.

To remove the program card, turn power to the VM-54 off and then press the lever in the card slot.

Output Connectors

AC Output

These connectors provide an AC output signal.

Output voltage:	1 V _{rms} ±20 mV _{rms} (at range full-scale)
Output impedance:	approx. 100 Ω
Load impedance:	10 kΩ or higher
Output connector type:	BNC
Suitable cable:	BNC-BNC cable NC-39A (1.5 m), optional

The output in calibration mode is 31.5 Hz, 1.0 V_{rms}.

Reference Information

About the external power switching jumper pins

The VM-54 is turned on by holding down the Power key for at least one second, but the on/off status can also be controlled by an external power supply without using the Power key.

Changing the setting of the external power switching jumper pins

1. Turn power off and disconnect the AC adapter or remove the batteries.
2. Open the battery compartment lid on the bottom panel.
3. Change the position of the jumper on the external power switching jumper pins from position A to position B.

External power switching jumper pins

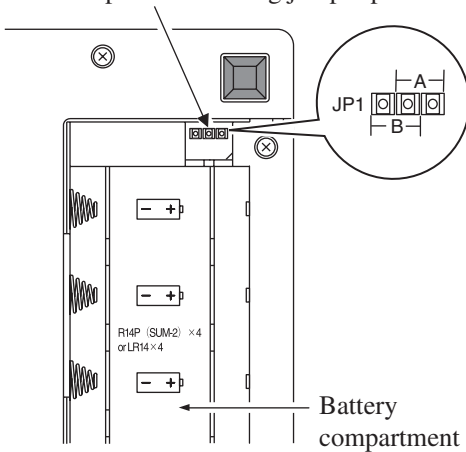

Jumper pin position

Side A:

Normal position (unit on/off is controlled by Power key)

Side B:

Unit operates in conjunction with external power supply

Caution

The external power switching jumper pins are small and pointed. Take care not to hurt your fingers.

Important

Never connect any equipment to the external power switching jumper pins. Otherwise damage may occur.

4. When you connect the AC adapter (option) and thereby supply power to the VM-54, the unit will automatically be turned on. This also applies when the unit is powered from batteries.

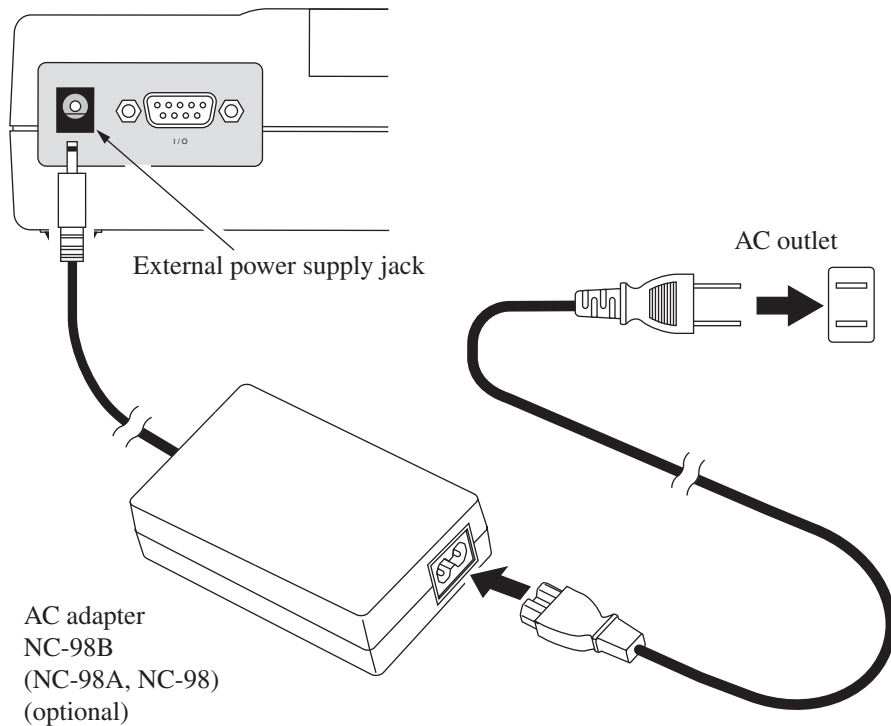

Important

Do not use any other kind of AC adapter except the NC-98B (NC-98A, NC-98). Otherwise damage may occur.

Note

The optional AC adapter NC-98B (NC-98A, NC-98) is for 100 to 240 V AC.

The VM-54 has a resume function (allowing it to start up with the same settings as selected before shutting down), but this function operates only when the unit is switched on and off with the Power key. It does not operate when external power switching is used.

Input connector

The input connector is a Tajimi Electronics connector 1108-23A10-7F wired as shown below.

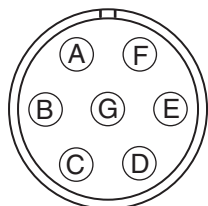

Top view

- A: +12 V
- B: Ground
- C: Z channel signal input
- D: -12 V
- E: X channel signal input
- F: Y channel signal input
- G: Power supply output from unit (AC adapter or batteries), or +7 V (when PV-83C/PV-83CW is selected)

Important

Do not connect anything else besides the optional 3-axis accelerometer PV-83C/PV-83CW, PV-57 (A) or a 3ch preamplifier VP-80 to this connector. Otherwise damage may occur.

Frequency characteristics

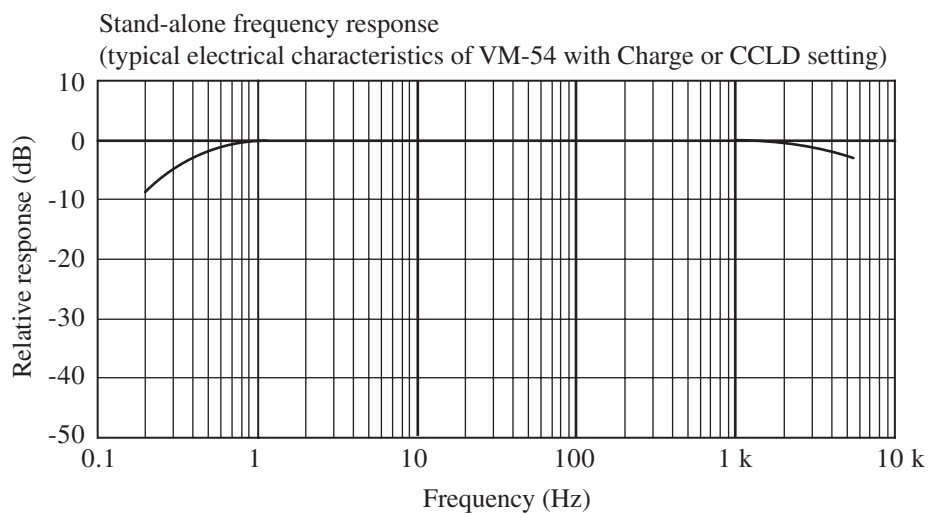
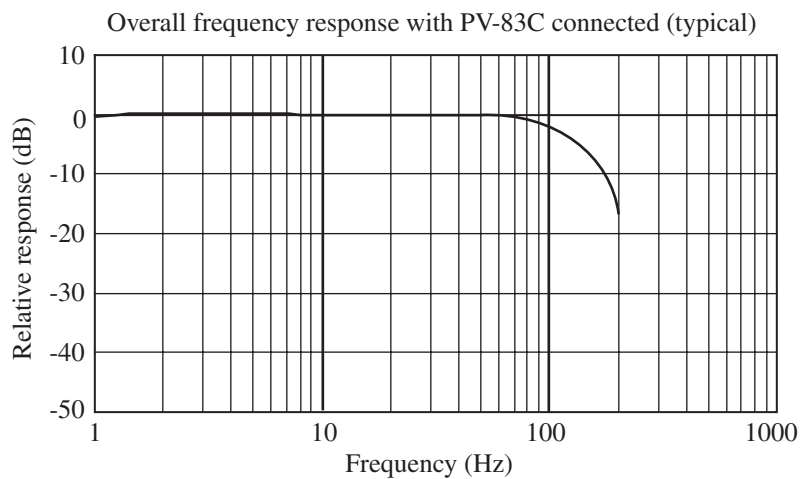

Specifications

Input section	7-pin connector, type 1108 For 3-axis accelerometer PV-83C/PV-83CW or 3ch preamplifier
Measurement mode	Acceleration: m/s^2
Sensitivity settings	10.0 to 99.9 $\text{pC}/(\text{m/s}^2)$ 1.00 to 9.99 $\text{pC}/(\text{m/s}^2)$ 0.100 to 0.999 $\text{pC}/(\text{m/s}^2)$ 0.0100 to 0.0999 $\text{pC}/(\text{m/s}^2)$ When the sensor type is CCLD, the unit is $\text{mV}/(\text{m/s}^2)$
Measurement range	With piezoelectric accelerometer Sensitivity setting 10.0 to 99.9 $\text{pC}/(\text{m/s}^2)$: 0.03, 0.1, 0.3, 1, 3, 10, 30, 100 Sensitivity setting 1.00 to 9.99 $\text{pC}/(\text{m/s}^2)$: 0.3, 1, 3, 10, 30, 100, 300, 1000 Sensitivity setting 0.100 to 0.999 $\text{pC}/(\text{m/s}^2)$: 3, 10, 30, 100, 300, 1000, 3000, 10000 Sensitivity setting 0.0100 to 0.0999 $\text{pC}/(\text{m/s}^2)$: 30, 100, 300, 1000, 3000, 10000 When the sensor type is CCLD, the unit is $\text{mV}/(\text{m/s}^2)$ With 3-axis accelerometer PV-83C/PV-83CW 0.03, 0.1, 0.3, 1, 3, 10
Measurement frequency range	0.5 Hz to 5 kHz 1 Hz to 80 Hz (with accelerometer PV-83C)
Overload indication	"Over" or "Under"

Displays	<p>Segment type LCD × 1 and 128 × 64 dot matrix type × 1 With backlight Display modes</p> <ul style="list-style-type: none"> · Segment type <ul style="list-style-type: none"> Single-axis measurement value and bar graph (100 ms update cycle) always shown Setting information display · Dot matrix type <ul style="list-style-type: none"> 3-axis instantaneous value and bar graph display Menu display
Data store function	<p>None</p> <p>When option program for marine vibration measurement, hand-transmitted vibration measurement, or whole-body vibration measurement is installed, data storage on CompactFlash is possible.</p>
Signal output connectors	<p>BNC connector × 3 for X, Y, Z (AC output) 1 Vrms at range full scale</p>
I/O connector	<p>9-pin D-sub male</p> <p>Serial transmission capability: none</p> <p>When option program for marine vibration measurement, hand-transmitted vibration measurement, or whole-body vibration measurement is installed, this connector serves for printer output.</p>
Power supply	<p>IEC R14 (size "C") battery × 4 or AC adapter (optional)</p>
Ambient conditions for use	<p>-10 to +50°C, max. 90% RH (no condensation)</p>
Dimensions and Weight	<p>200 × 175 × 56 mm, approx. 690 g (not including batteries)</p>

Supplied accessories	IEC R14 (size "C") battery	4
	Instruction manual	1
	Inspection certificate	1
Optional accessories	Carrying case	
	AC adapter	NC-98B (NC-98A, NC-98)
	3ch preamplifier	VP-80
	3-axis accelerometer	PV-83C/PV-83CW
	VM-54 PV-83C cable	EC-54
	Extension cables	EC-04 series
	Battery pack	BP-21
	Marine Vibration Card	VX-54WS

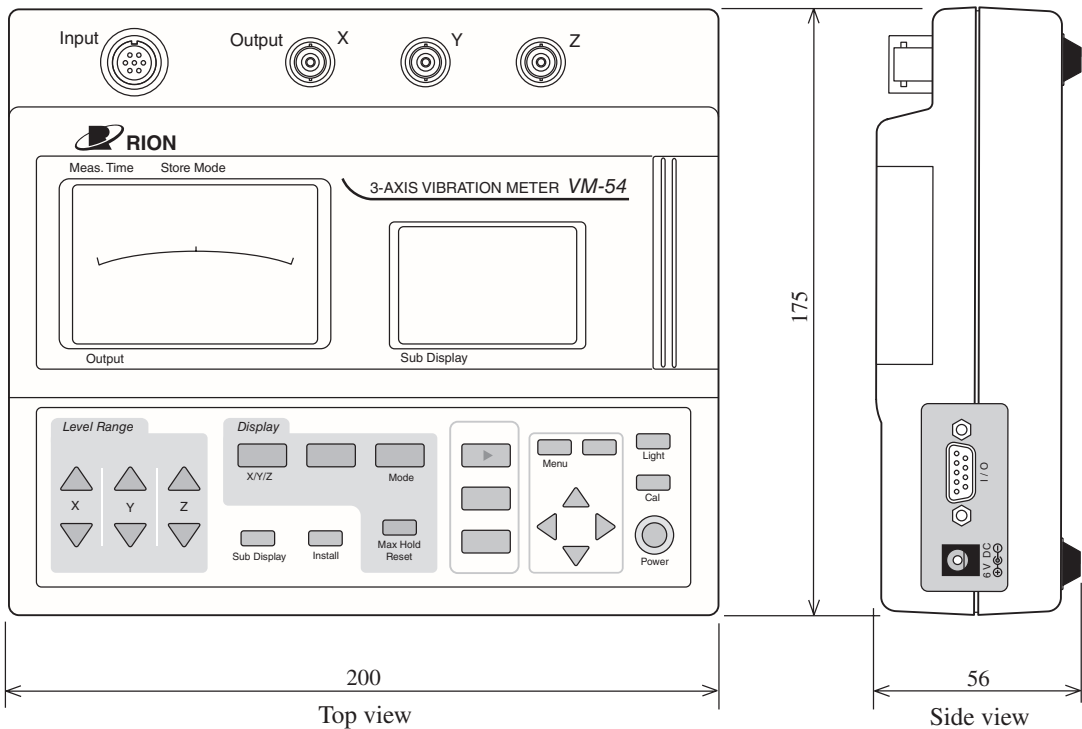

Unit: mm

Dimensional drawing of 3-Axis Vibration Meter VM-54

